

Surge Protective Devices

**LowProfile Series:
080 and 120**

**Installation,
Operation and
Maintenance
Manual**



TABLE OF CONTENTS

Before Installation	3-5
<i>System Configuration Verification</i>	3
<i>Wiring Connection Diagrams</i>	4
<i>Upstream Over-Current Protection Device</i>	4
<i>Conductor Routing</i>	4
<i>Conductor Openings</i>	4-5
<i>Mounting</i>	5
<i>Optional Flush-Mount Plate</i>	5
Connection and Wiring Instructions	6-8
<i>Phase, Neutral and Ground Connections</i>	6
<i>Connecting Form C Dry Contacts</i>	6-7
<i>Neutral to Ground Filter Jumper</i>	7
<i>Verification and Power Up</i>	8
Troubleshooting	9
Technical Assistance	9
Returns and Warranty Procedures	9
Warranty Statement	10

BEFORE INSTALLATION



WARNING: HAZARDOUS VOLTAGES PRESENT Improper installation or misapplication may result in serious personnel injury and/or damage to electrical system. Read the complete installation instructions before proceeding with installation. Remove all power to the electrical panel before installing or servicing the surge protective device (SPD).



IMPORTANT SAFETY INSTRUCTIONS All work must be performed by licensed and qualified personnel. The electrical system must be properly grounded in accordance with the U.S. National Electrical Code, state and local codes or other applicable codes for this SPD to function properly. Do not connect LowProfile (LP) to the line side of the main service breaker or disconnecting means. This device is suitable for installation where the available short circuit current is 200,000 rms symmetrical amperes at 600VAC or less.

1. System Configuration Verification

Confirm that the voltage(s) and service configuration shown on the LowProfile product label are consistent with the voltage and service configuration of the facility. A model number is on the left side of the LowProfile unit. Each model number corresponds to the configurations printed in the table below:

Example of LowProfile model number: TK-LP080-3Y208-FL

MODEL NUMBER	NOMINAL VOLTAGE	L-N VOLTAGE RANGE	L-L VOLTAGE RANGE	CONFIGURATION
TK-LPxxx-1S240-L	120/240	108-132	216-264	Split-Phase, 3-wire+ground
TK-LPxxx-3Y208-L	120/208	108-132	187-229	Three-Phase WYE, 4-wire+ground
TK-LPxxx-3Y480-L	277/480	249-305	432-528	Three-Phase WYE, 4-wire+ground
TK-LPxxx-3D240-L	120/240	108-132 (A & C Phases) 187-229 (B Phase)	216-264	Three-Phase high-leg Delta, 4-wire+ground

xxx denotes surge rating per phase (080, or 120)

Enhanced Transient Filter: add suffix "-F"



WARNING: Check to ensure that a proper bond is installed between neutral and ground at the transformer upstream from all 3-phase WYE or split-phase LowProfile device (See NEC Article 250). If the transformer is not accessible, check the main service disconnect/panel for the N-G bond. Lack of a proper bond will damage LowProfile and void the warranty.

2. Wiring Connection Diagrams

Figure 3 shows the electrical relationship between LowProfile and these three basic service configurations: Split phase, 3-wire, Three-phase, 4-wire WYE, and Three-phase, 4-wire high-leg Delta.

Fig. 1: Split Phase, 3-Wire

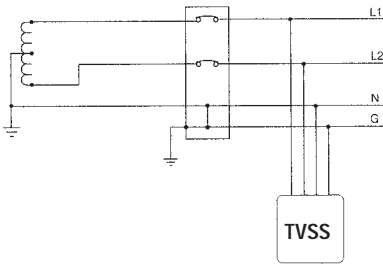

Fig. 2: 3-Phase, 4-Wire WYE

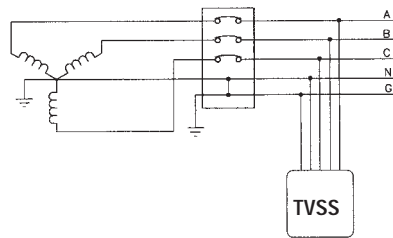
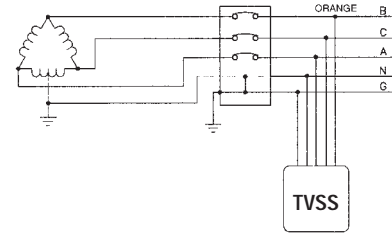

Fig. 3: 3-Phase, 4-Wire High-Leg DELTA



Connections to the SPD are clearly identified. Connections are made via pigtail leads supplied with the unit. For 3 phase units phases A, B and C are black wires, which are marked “Phase A”, “Phase B” and “Phase C” respectively. For split phase units, the phase connections are marked “Phase A” and “Phase B”. The neutral is a white wire and the ground is a green/yellow wire.

3. Upstream Over-Current Protection Device

LowProfile must be connected in parallel with the electrical system. All LowProfile units come standard with component-level over-current fusing rated at 200,000 rms symmetrical amperes at 600VAC. The SPD can be connected directly to the electrical system bus and does not require an upstream over-current protection device.



CAUTION: LowProfile’s performance will be limited severely if the conductors are (a) too long, (b) are of too small a wire gauge, (c) have too many bends or (d) have sharp bends.

4. Conductor Routing

The factors listed above should be addressed during the design of an installation to reserve a suitable place for LowProfile next to its point of connection to the electrical system. The selected mounting location should allow for the shortest possible conductor runs and a direct route with a minimum of bends. If bends are required, they should be sweeping bends. Do not make sharp 90° bends for appearance purposes because they will severely decrease the effectiveness of LowProfile.

Binding or twisting conductors together using tie-wraps or electrical tape increases the protection performance of the device.

5. Conduit Openings

All LP units come with a 3/4” conduit hub and chase nipple. There are three conduit openings located in top, top left, and top right sides of the enclosure. The hub can be installed in any of the three openings. The remaining unused openings can be covered with supplied knock-out seals.

Fig. 4 Conduit Openings, Enclosure Mounting, and Dimensions

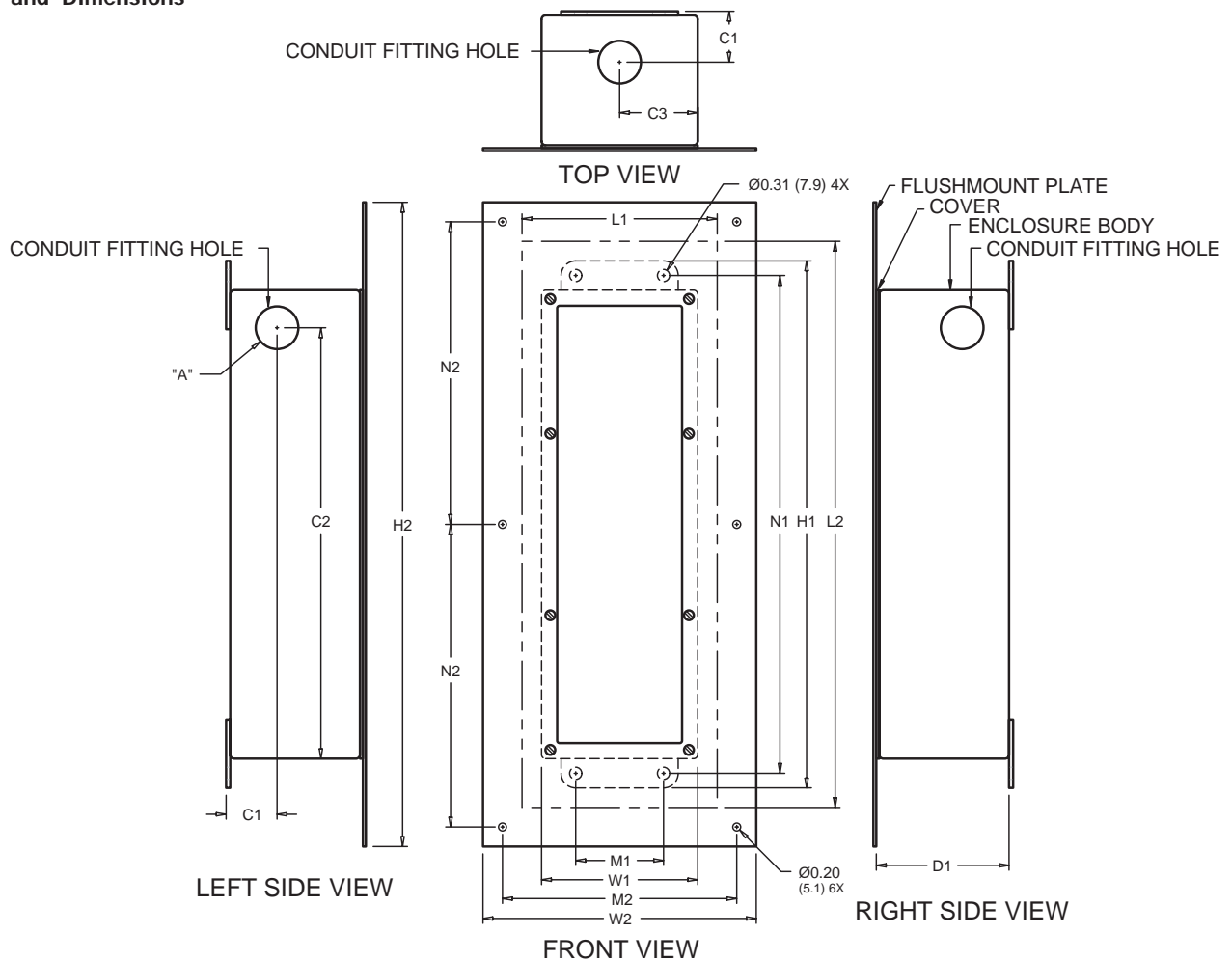

MODEL SERIES	OVERALL DIMENSIONS - IN (mm)			MOUNTING HOLES		CONDUIT FITTING			
	H1	W1	D1	M1	N1	TRADE SIZE	LOCATIONS		
TK-LP080/120	13.50 (342.9)	4.00 (101.6)	3.50 (88.9)	2.25 (57.2)	12.75 (323.9)	3/4 (19.0)	C1	C2	C3
							WALL CUTOUT		
	H2	W2		M2	N2		L1	L2	
FLUSHMOUNT PLATE	16.50 (419.1)	7.00 (177.8)		6.00 (152.4)	7.75 (196.9)		5.00 (127)	15.50 (368.3)	

6. Mounting

LowProfile can be mounted in a variety of methods. The basic method is to wall mount using the mounting feet attached to the base of the enclosure. LowProfile can also be mounted even (or flush-mount) to the exterior wall surface. Mount LowProfile using construction methods and hardware appropriate for your site. Install the conduit hub, chase nipple and pull conductors as specified above or according to the engineer's design. See Figure 3 for enclosure and mounting dimensions.

7. Optional Flush-Mount Plate

Optional flush-mount plate, part number LP-FMP, can be purchased for flush-mount installation. Typically a cutout, larger than the LowProfile enclosure, is created in the drywall or other finish material. See Figure 4 for the recommended cutout gap (dimensions L1 and L2). Use the flush-mount plate to hide the gap between the enclosure and the cutout edges. Prior to installation, attach the plate to the enclosure using the existing cover screws.

CONNECTION AND WIRING INSTRUCTIONS

1. Phase, Neutral, and Ground Connections

NOTE: In order to connect the LowProfile unit, it will be necessary to remove the cover of the unit. Use care when removing the cover, as there are wires, which run from components on the cover to inside the enclosure of the SPD. The monitor board (located on the backside of the cover) has a cable harness which routes into the enclosure.



CAUTION: Prior to installation ensure the system configuration and voltage is equivalent to the LowProfile unit being installed.

Following all applicable National Electrical Code standards as well as state and local codes, connect phase, neutral and ground to LowProfile. Ensure that the conductor lengths are kept as short and straight as possible. On all high-leg systems, the phase B conductor of the suppressor (color-coded orange according to NEC) must be connected to the high-leg.

2. Connecting Form C Dry Contacts

All LowProfile units come standard with one set of Form “C” dry relay contacts for the SPD status. These contacts are for connection to a user-provided remote alarm and monitoring circuit. The relay contacts are rated 65VDC/150VAC with maximum switching power of 30WDC/60VA AC. See Figure 5 for the form C contact configuration and terminal location on the monitor board. The annotations on the diagram match the markings on the terminal block.

When input power is present on all phases, terminals “NO” and “COM” are an open circuit and terminals “NC” and “COM” are a closed circuit. The contacts change state when the unit has encountered failure to one or more phases.

The installer must provide the appropriate raceway and wiring for the monitoring circuit, observing the restrictions and conduit openings illustrated in an earlier section of this manual. The installer must route the monitoring conductors to the terminal blocks on the lid-mounted main monitoring board. Route the wires to allow the lid to be opened and closed properly. Tighten screws on terminals to 3.5 in-lbs (0.4 Nm). This terminal block will accept wire sizes #28AWG to #16AWG. #18AWG to #20AWG is recommended.

Fig. 5 Remote Monitoring Terminal Block

Contacts shown in energized normal state.
(no fault condition)

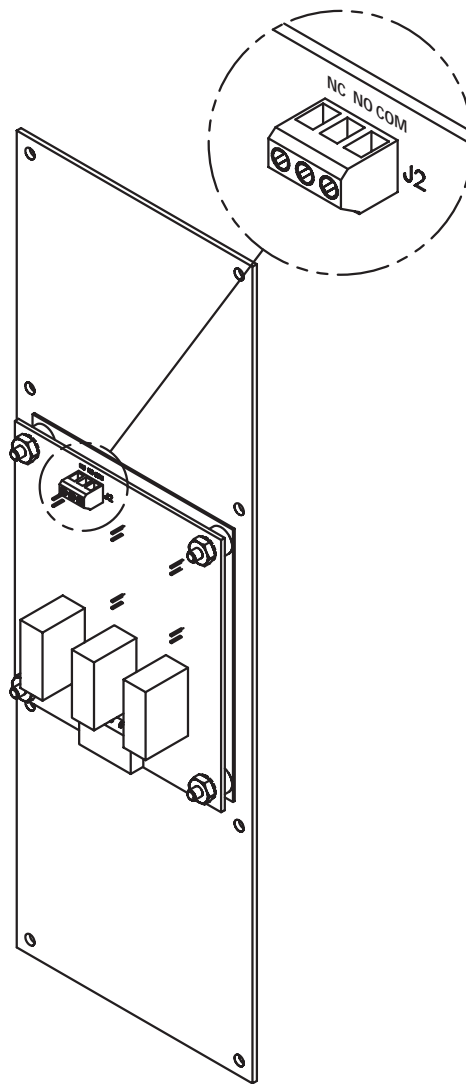

3. Neutral to Ground Filter Jumper

All LowProfile models with enhanced filter (model numbers end with “-F” suffix) come with a green jumper wire, which loops out of the epoxy and connects the filter from neutral to ground. In certain medical applications or circuits which employ GFCI protection, this Neutral to Ground filter connection should be removed.



WARNING: Prior to proceeding, ensure the LowProfile unit does not have voltage applied to its input terminals

Removal is accomplished by cutting the green jumper wire. Once cut, both ends should be properly separated and insulated to prevent the ends from making inadvertent electrical contact.

TROUBLESHOOTING

Your LowProfile system does not require scheduled maintenance. The unit's heavy-duty construction is designed to provide years of uninterrupted service. The unit contains no serviceable parts.

INDICATION	PROCEDURE
One or more phase protection status indicating lights are off, check system indicating light is on and form C alarm contacts have changed state	Verify that the input power feeding LowProfile is energized using a voltage tester. If power is present, contact factory for assistance: 800-647-1911

TECHNICAL ASSISTANCE

Our staff is ready to support you and answer any questions.
Monday through Friday, 8:00 a.m. to 5:00 p.m. (EST) at 800-647-1911

RETURNS AND WARRANTY PROCEDURES

LowProfile products are warranted for a period of 30 years from date of purchase. In the event that any module or subassembly within the SPD fails to perform as specified during the warranty period, call our Technical Support at 800-647-1911 to obtain a Return Material Authorization number. We will immediately ship a replacement for the defective parts free of charge (installation labor and site preparation excluded). Return the defective parts to Joslyn within 30 days of receiving the replacement. Failure to return the defective parts will result in billing for the replacement parts. To help expedite the return procedures, please have the following information at hand when you contact Joslyn:

INFORMATION	EXAMPLE
Model Number	TK-LP120-3Y208-L
Serial Number	15478-1404-001
Date of Purchase	March 30, 2004 (14th week)
Sales Order Number	15478
Description of Failure	"Check System" indicating light illuminated
Desired Action from Joslyn	Replace

